

TO INSTALL 1" (2.54CM) BAY WINDOW CURTAIN ROD

Form No. 64228

637912

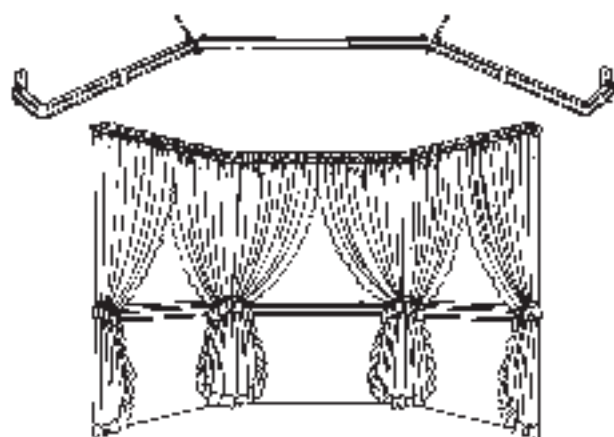

SIDE RODS (2)
29 1/2" - 75"
(74.93CM - 190.48CM)

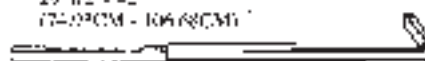

OPTION FOR SIDES (2)
18" - 45.72CM
24" - 60.96CM



CENTER ROD - 36" - 91.41CM (91.02CM)



BRACKETS, LEFT AND RIGHT

SUPPORTS (2)

THREADER (1)



SCREWS (4)

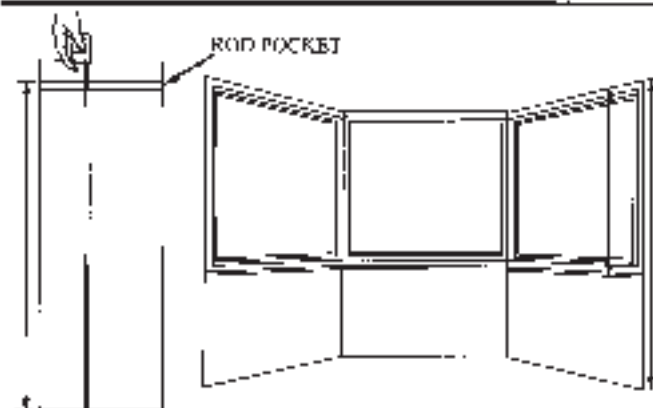

Lay panel flat. Measure length from bottom hinge to top of rod pocket. Write measurement here. _____

Using this figure, measure up from where you want the hew to be. Mark wall or frame with pencil.

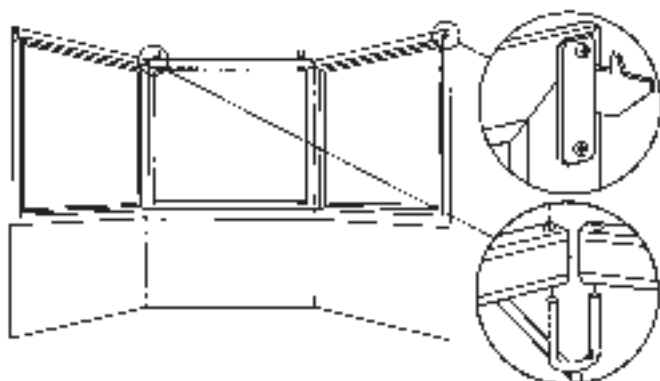

Mount brackets. Top bracket hole must line up with mark made in Step 2. Support wire screws must line up with bottom hole on end brackets.

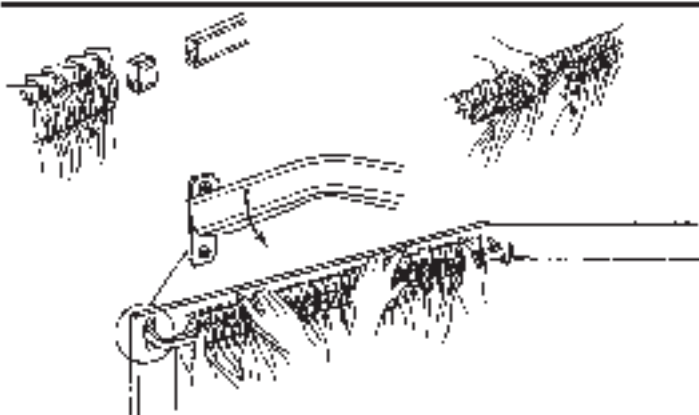

Put threader over end of larger rod section. Slip curtains over rod. Hold rod vertically when shirring curtains to avoid the rod from bending.

Put top hole of left end rod over prong on bracket. Swing rod down and snap on prong. Carefully put rods on support arms. Gently extend rod and attach to bracket at right end. Two people should mount rods over 36" (91.44cm).

COMO INSTALAR UNA BARRA DE 2.54CM (1") PARA VENTANA SALIENTE

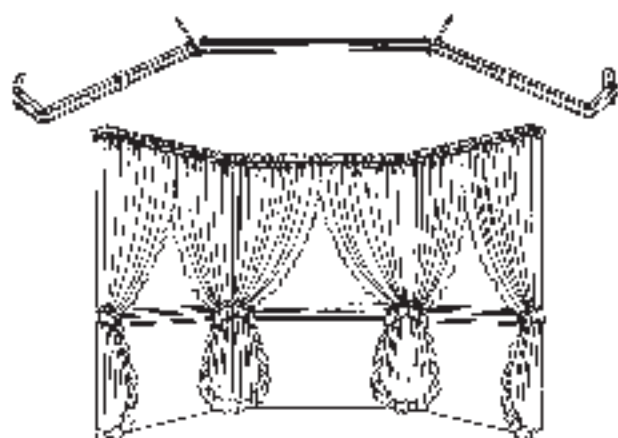

(2) SECCIONES PARA LOS BRAZOS

45.72CM (1.83CM)

(18" - 29/32")

(2) BARRAS LATERALES

74.93CM (29.50CM)

(29 1/2" - 41")

(1) BARRA CENTRAL (1.43CM - 16.00CM (56" - 63"))



SOPORTES:

(2) DOBLADO Y DOBLADO

(2) MENSULAS

(3) ENHEBRADOR



(4) TORNILLOS

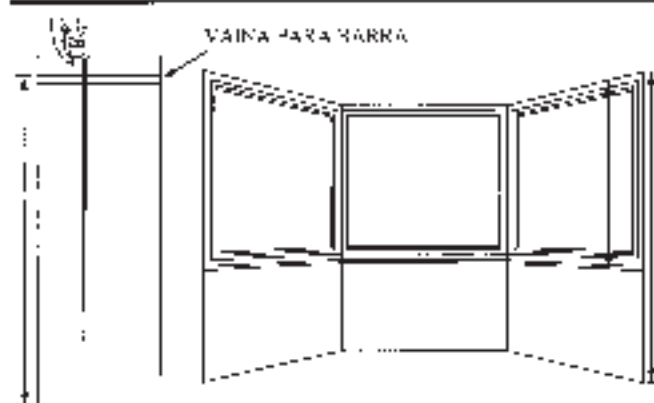
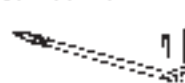

Tienda el panel. Mida la longitud entre el dobladillo inferior y el borde superior de la vaina para barra. Escríbalo a medida aquí.

Teniendo en cuenta este número, mida desde dónde quiere el dobladillo hacia arriba. Marque la pared o el marco con un lápiz.

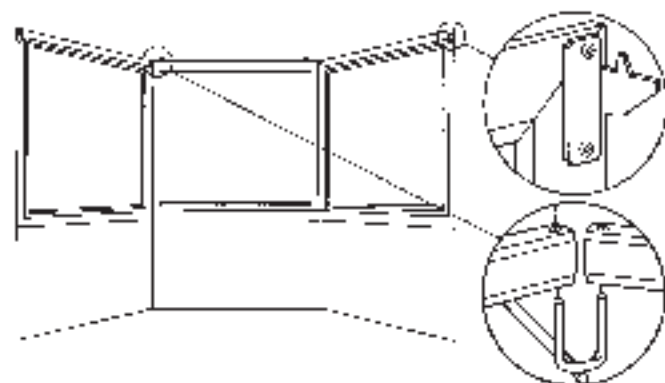

Monte los soportes. El agujero superior del soporte debe estar alineado con la marca hecha en el paso 2. Los tornillos de las ménsulas deben alinearse con el agujero inferior de los soportes de los extremos.

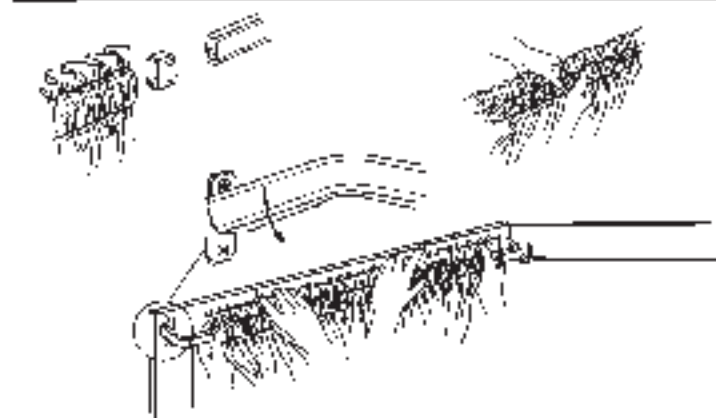

Coloque el enhebrador en el extremo de la sección más ancha de la barra. Deslice las cortinas en la barra. Sostenga la barra verticalmente mientras frunce las cortinas para evitar que ésta se doble.

Encaje el agujero superior de la barra lateral izquierda en la púa del soporte. Voltee la barra hacia abajo y cierre con un chasquido sobre la púa. Con cuidado, coloque las barras sobre los brazos de las ménsulas. Extienda la barra con precaución, y una al soporte del extremo derecho. Dos personas deben montar las barras de más de 91.44cm (36").